

Rev	AWO #	Description	Date	Appr
-		RELEASED	12/03/10	

APPROVED: _____
 DATE: _____ TITLE: _____

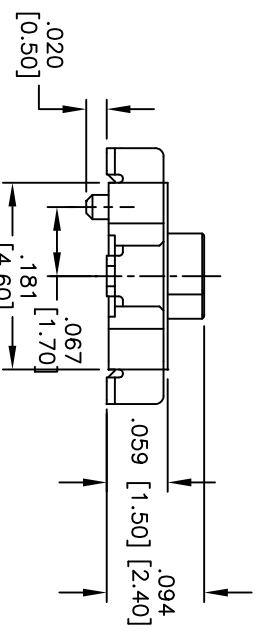
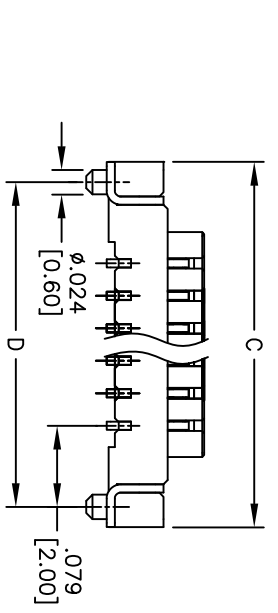
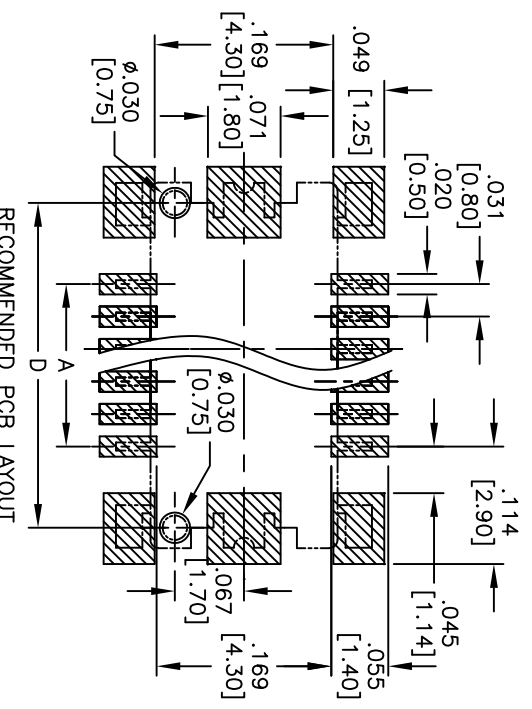
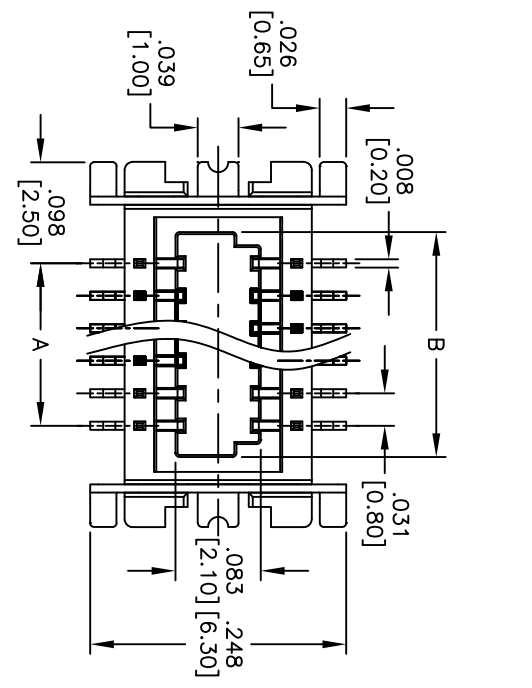

PACKAGED ON TAPE & REEL

SPECIFICATIONS:
 Material: Insulator: Hi-temp thermoplastic, rated UL 94V-0
 Insulator color: Natural
 Contacts: Copper Alloy
 Hold down: Copper Alloy
 Plating: Gold flash over Nickel underplate overall.
 Electrical: Operating voltage: 50 VAC max
 Current rating: 0.5 Amps max
 Contact resistance: 30 mohms max. initial
 Insulation resistance: 500 Mohms min
 Environmental: Lead free, RoHS compliant
 Recommended soldering temp: 260°C for 5 seconds

Positions: 10 thru 30
 A = .031 [0.80] x (No. of Contacts per row - 1)
 B = .031 [0.80] x (No. of Contacts per row - 1) + .061 [1.54]
 C = .031 [0.80] x (No. of Contacts per row - 1) + .197 [5.00]
 D = .031 [0.80] x (No. of Contacts per row - 1) + .157 [4.00]

ADAM TECH
 909 Rahway Avenue, Union, NJ 07083
 Phone: 908-687-5000 Fax: 908-687-5710



UNLESS OTHERWISE SPECIFIED ALL DIMENSIONS ARE INCHES [MM] TOLERANCES: EXCEPT AS NOTED INCHES		Holes		DATE	
.X	± .10	ØXX	± .10		
.XX	± .020	ØXXX	± .015		
.XXX	± .015	ØXXXX	± .010		
DRAWN DY 12/03/10					
CHECKED					
APPROVED					
TITLE		SIZE	PART NO.	SCALE	SHEET 1 OF 1
.031 [0.80] BOARD TO BOARD SOCKET, SMT TYPE		X	BB8-SEA-XX-G-2-40-T/R	NTS	
2.40MM HEIGHT, STACKING HEIGHT=3.5MM, 4.2MM					