

Rev	AWO #	Description	Date	Appr
-		RELEASED	9/30/11	

APPROVED: _____
 DATE: _____ TITLE: _____

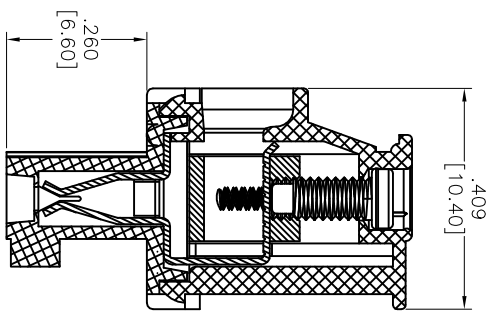
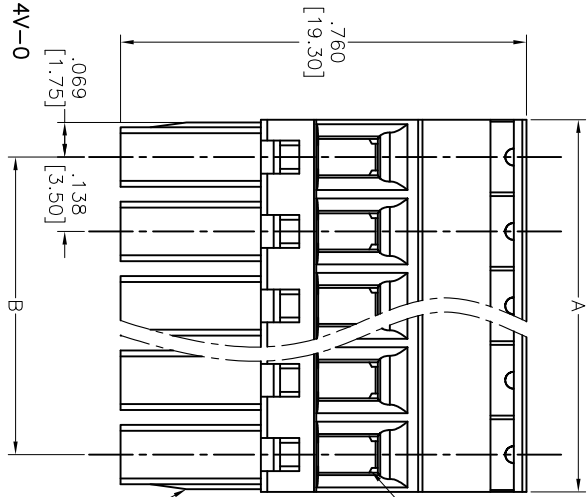
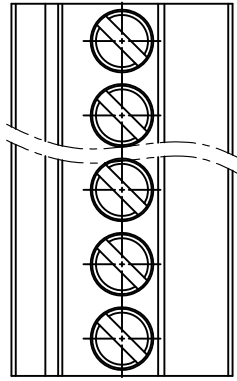

2p to 6p with wedge, above 7p
 without wedge (including 7p)

Positions: 2 thru 24
 A = .138 [3.50] x No. of Positions
 B = .138 [3.50] x No. of Spaces

Positions	Tolerance
2-8P	±.004 [0.10]
9-16P	±.008 [0.20]
17-24P	±.012 [0.30]

SPECIFICATIONS:

- Material:** Insulator: Thermoplastic, rated UL 94V-0
- Insulator color: Green
- Clamp: Brass, Nickel plated
- Contact: Phosphor Bronze, Tin plated
- Screw: Steel, M2/Zn plated
- Electrical:** Operation voltage: 300 VAC
- Current rating: 8 Amps
- Withstanding Voltage: 1.6KV
- Mechanical:** Wire range (mm²): 1.5
- Solid wire (AWG): 16-28
- Stranded wire (AWG): 16-28
- Torque (Lb-in): 1.7
- Wire strip length (mm): 6-7
- Temperature Rating: Operating temperature: -40°C to +115°C
- Environmental: Lead free, RoHS compliant.
- Recommended soldering temp: 250°C for 5 sec.



UNLESS OTHERWISE SPECIFIED
 ALL DIMENSIONS ARE MM [INCHES]
 TOLERANCES: EXCEPT AS NOTED

INCHES	HOLES
.X ±.10	ØX ±.10
.XX ±.020	ØXX ±.015
.XXX ±.015	ØXXX ±.010

ADAM TECH
 909 Railway Avenue, Union, NJ 07083
 Phone: 908-687-5000 Fax: 908-687-5710

EURO BLOCK, .138 [3.50] PITCH

APPROVALS	DATE
DRAWN TW	9/30/11
CHECKED AY	9/30/11
APPROVED	

SIZE	PART NO.	REV.
X	EB5-XX-A	-

REF: S00007T SCALE: NTS SHEET 1 OF 1