

Rev	AWO #	Description	Date	Appr
-		RELEASED	10/21/11	

APPROVED: _____ TITLE: _____
 DATE: _____

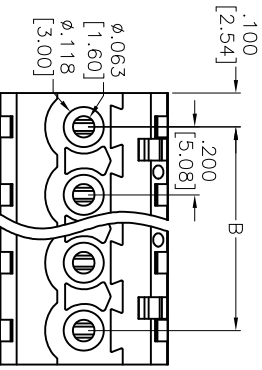
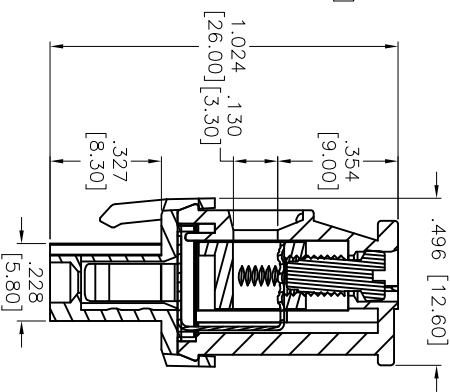
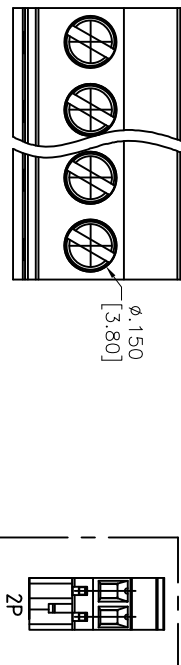

Positions: 2 thru 24
 A = .200 [5.08] x No. of Positions
 B = .200 [5.08] x No. of Spaces

Positions	Tolerance
2-6P	±.006 [0.15]
7-12P	±.010 [0.25]
13-18	±.012 [0.30]
19-24P	±.016 [0.40]

SPECIFICATIONS:

Material:
 Insulator: Thermoplastic, rated UL 94V-0
 Insulator color: Black
 Clamp: Brass, Nickel plated
 Contact: Phosphor Bronze, Tin plated
 Screw: Steel, M3/Zn plated

Electrical:
 Operation voltage: 300 VAC
 Current rating: 15 Amps
 Withstanding Voltage: 1.6KV

Mechanical:
 Wire range(mm²): 2.5
 Solid wire(AWG): 12-24
 Stranded wire(AWG): 12-24
 Torque(Lb-in): 3.5
 Wire strip length(mm): 6-7
 Temperature Rating:
 Operating temperature: -40°C to +115°C
 Environmental:
 Lead free, RoHS compliant.
 Recommended soldering temp: 250°C for 5 sec.

ADAM TECH

909 Rahway Avenue, Union, NJ 07083
 Phone: 908-687-5000 Fax: 908-687-5710

TITLE: EURO BLOCK, 2.00 [5.08] PITCH, BLACK
 WILATCHING HOOKS ON THE WIRE ENTER SIDE

UNLESS OTHERWISE SPECIFIED ALL DIMENSIONS ARE INCHES [MM]	
.X	±.10
.XX	±.020
.XXX	±.015
.XXX	±.015
.XXX	±.010

APPROVALS	DATE
DRAWN TW	10/21/11
CHECKED AY	10/21/11
APPROVED	

REF: S00007T	SCALE: NTS	SHEET 1 OF 1
--------------	------------	--------------

