

Rev	AWO #	Description	Date	Appr
-		RELEASED	11/07/11	

APPROVED: \_\_\_\_\_  
 DATE: \_\_\_\_\_ TITLE: \_\_\_\_\_

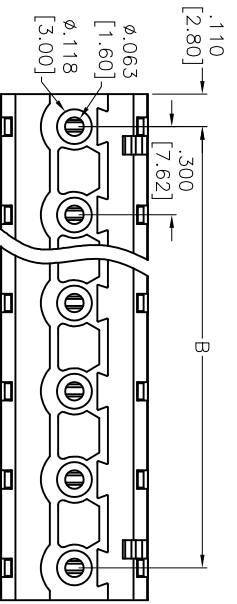
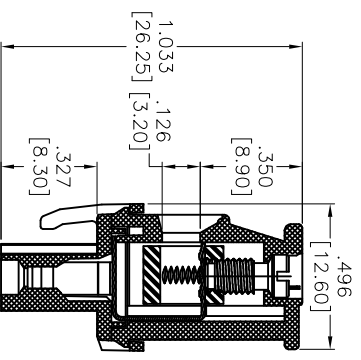
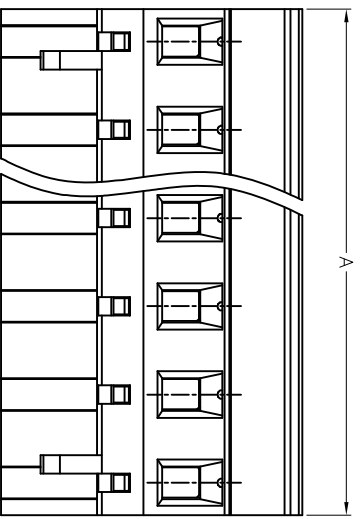
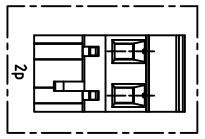
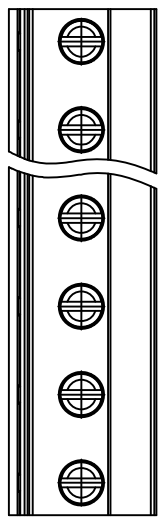

Positions: 2 thru 16  
 A = .300 [7.62] x No. of Spaces + .200 [5.60]  
 B = .300 [7.62] x No. of Spaces

2-6P	±.008 [0.20]
7-11P	±.012 [0.30]
12-16P	±.016 [0.40]

# ADAM TECH

909 Railway Avenue, Union, NJ 07083  
 Phone: 908-687-5000 Fax: 908-687-5710

**EURO BLOCK, .300 [7.62] PITCH, BLACK  
 HOOKS ON ENTRY SIDE**

**SPECIFICATIONS:**  
 Material: Insulator: Thermoplastic, rated UL 94V-0  
 Insulator color: Black  
 Clamp: Brass, Nickel plated  
 Contact: Phosphor Bronze, Tin plated  
 Screw: Steel, M3/Zn plated

**Electrical:**  
 Operation voltage: 300 VAC  
 Current rating: 15 Amps  
 Withstanding Voltage: 1.6KV

**Mechanical:**  
 Wire range(mm<sup>2</sup>): 0.2~2.5  
 Solid wire(AWG): 12-24  
 Stranded wire(AWG): 12-24  
 Torque(Lb-in): 3.5  
 Wire strip length(mm): 6-7  
 Temperature Rating:  
 Operating temperature: -40°C to +115°C  
 Environmental:  
 Lead free, RoHS compliant.  
 Recommended soldering temp: 250°C for 5 sec.



UNLESS OTHERWISE SPECIFIED ALL DIMENSIONS ARE INCHES [MM]	
TOLERANCES EXCEPT AS NOTED	HOLE
.X ±.10	ØX ±.10
.XX ±.020	ØXX ±.015
.XXX ±.015	ØXXX ±.010
APPROVALS	DATE
DRAWN AY	11/07/11
CHECKED TW	11/07/11
APPROVED	

TITLE	EURO BLOCK, .300 [7.62] PITCH, BLACK HOOKS ON ENTRY SIDE
SIZE	X
PART NO.	EB9-XX-G-BK
REF:	S00007T
SCALE:	NTS
SHEET	1 OF 1
REV.	-