

Rev	AWO #	Description	Date	Appr
-		RELEASED	11/07/11	

APPROVED: _____
 DATE: _____ TITLE: _____

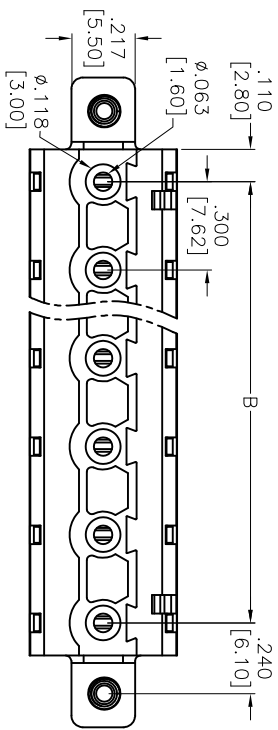
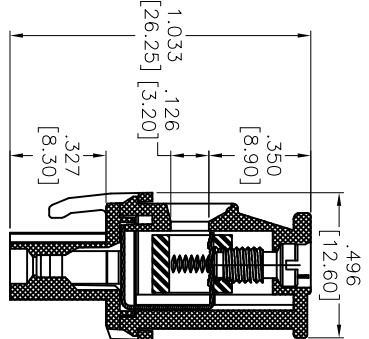
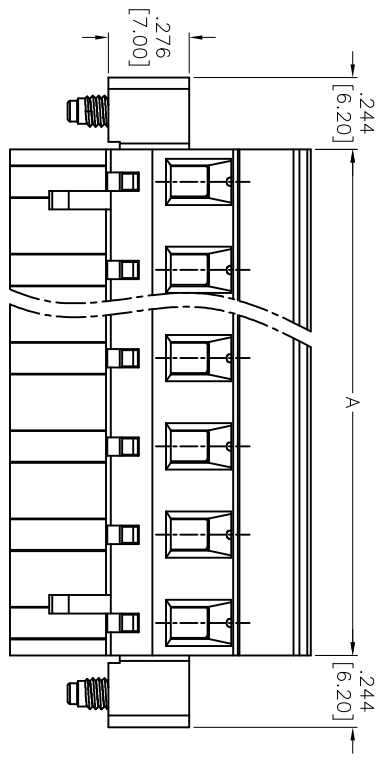
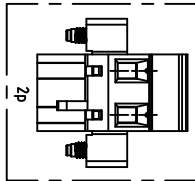
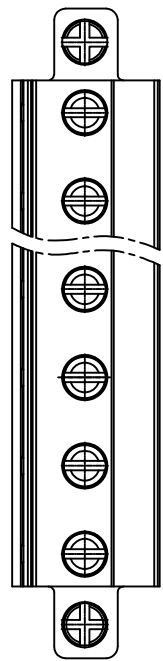

Positions: 2 thru 16
 A = .300 [7.62] x No. of Spaces + .200 [5.60]
 B = .300 [7.62] x No. of Spaces

	Tolerance
2-6P	±.008 [0.20]
7-11P	±.012 [0.30]
12-16P	±.016 [0.40]

SPECIFICATIONS:

Material:
 Insulator: Thermoplastic, rated UL 94V-0
 Insulator color: Black
 Clamp: Brass, Nickel plated
 Contact: Phosphor Bronze, Tin plated
 Screw: Steel, M3/Zn plated
 With flange Screw: Steel, M2.05/Zn plated

Electrical:
 Operation voltage: 300 VAC
 Current rating: 15 Amps
 Withstanding Voltage: 1.6KV

Mechanical:
 Wire range(mm²): 0.34~2.5
 Solid wire(AWG): 12-24
 Stranded wire(AWG): 12-24
 Torque(Lb-in): 3.5
 Wire strip length(mm): 6-7
 Operating temperature: -40°C to +115°C
 Temperature Rating:
 Environmental:
 Lead free, RoHS compliant.
 Recommended soldering temp: 250°C for 5 sec.

ADAM TECH

909 Railway Avenue, Union, NJ 07083
 Phone: 908-687-5000 Fax: 908-687-5710

TITLE: EURO BLOCK, .300 [7.62] PITCH, BLACK HOOKS ON ENTRY SIDE, WITH FLANGE

UNLESS OTHERWISE SPECIFIED ALL DIMENSIONS ARE IN INCHES [MM]	
TOLERANCES: EXCEPT AS NOTED	HOLE
.X ±.10	ØX ±.10
.XX ±.020	ØXX ±.015
.XXX ±.015	ØXXX ±.010
APPROVALS	DATE
DRAWN AY	11/07/11
CHECKED TW	11/07/11
APPROVED	

SIZE	PART NO.	REV.
X	EB9-XX-G-E-BK	-
REF:	SCALE: NTS	SHEET 1 OF 1

