

Rev	AWO #	Description	Date	Appr
-	-	RELEASED	01/04/07	BAS

APPROVED: _____
 DATE: _____ TITLE: _____

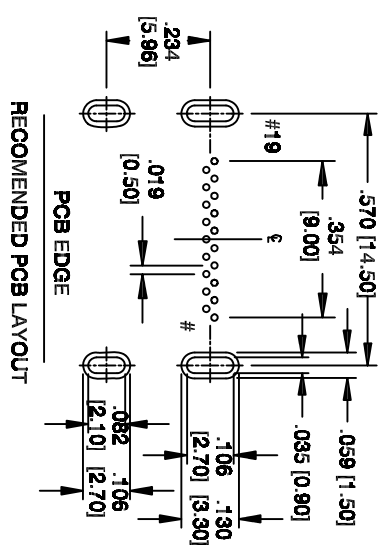
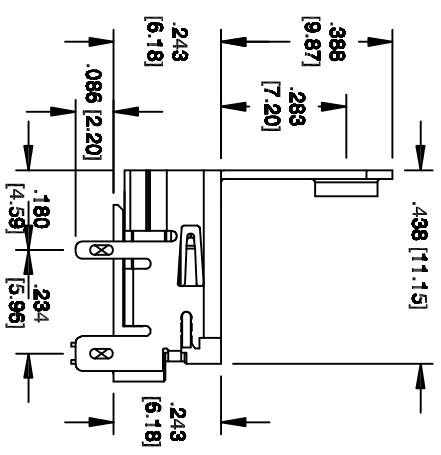
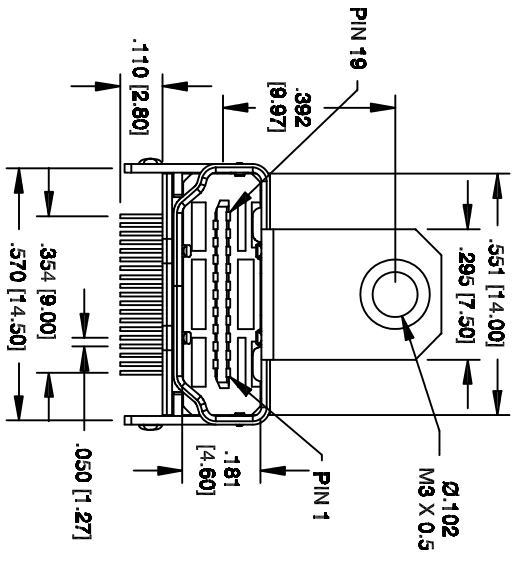
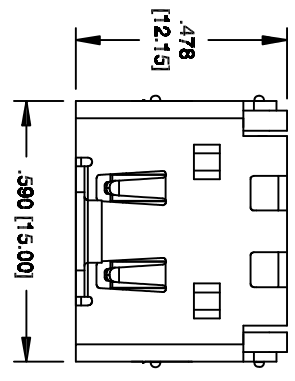

SPECIFICATIONS:

MATERIALS:
 HOUSING: THERMOPLASTIC, UL94V-0, COLOR: BLACK
 CONTACT: BRASS
 SHELL: PHOSPHOR BRONZE
 PLATING:
 CONTACT: 15u" GOLD
 TAILS: 100u" TIN (LEAD FREE) 50u" NICKEL UNDERPLATE
 SHELL: 50u" NICKEL
Environmental:
 Lead free, RoHS Compliant



UNLESS OTHERWISE SPECIFIED ALL DIMENSIONS ARE INCHES [MM]	
TOLERANCES: EXCEPT AS NOTED	
INCHES	HOLES
.X ± .10	Ø.X ± .10
.XX ± .020	Ø.XX ± .015
.XXX ± .015	Ø.XXX ± .010
APPROVALS	DATE
DRAWN	BW
CHECKED	
APPROVED	

ADAM TECH
 909 Railway Avenue, Union, NJ 07083
 Phone: 908-687-5000 Fax: 908-687-5710

TITLE: **HDMI, RIGHT ANGLE, DIP CONNECTOR**

SIZE	PART NO.	REV.
X	HDMI-S-RAMF	-
REF:	SCALE: NTS	SHEET 1 OF 1