

Rev	AWO #	Description	Date	Appr
-		RELEASED	4/14/08	

APPROVED: _____
 DATE: _____ TITLE: _____

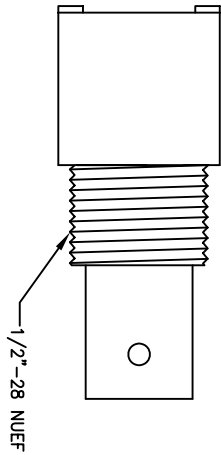

RECOMMENDED
 PC Board Layout
 Right Angle Mount

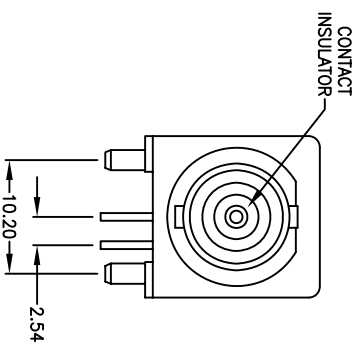
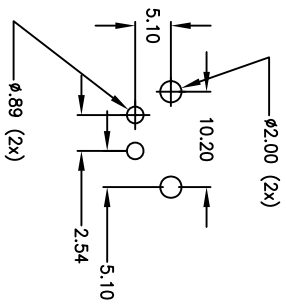

RECOMMENDED
 PANEL CUTOUT

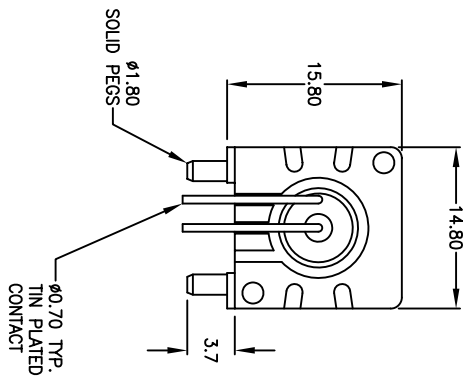
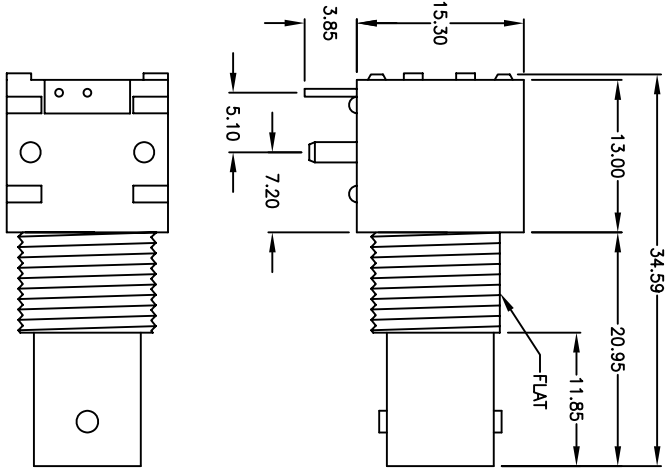
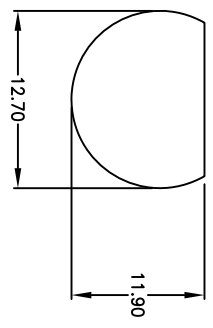

SPECIFICATIONS

Material:
 Body: PBT, Color Black
 Contact insulation: Polypropylene, color white.
 Contacts: Phosphor Bronze, Gold and Tin plated.
 Body: Polypropylene

Electrical
 Nominal Impedance: 75 Ohms
 Frequency Range: 0 – 4 GHz
 Maximum Peak Voltage: 500V
 Insulation Resistance: 5000 Mohms min @ 500 VDC
 Dielectric Withstanding Voltage: 1500 VAC rms.

Environmental:
 Lead free, RoHS compliant.
 Recommended soldering temp: 235 for 5 sec.



UNLESS OTHERWISE SPECIFIED ALL DIMENSIONS ARE MM [INCHES] TOLERANCES: EXCEPT AS NOTED	
INCHES	HOLES
.X ± .10	ØXX ± .10
.XX ± .020	ØXXX ± .015
.XXX ± .015	ØXXXX ± .010
APPROVALS	DATE
DRAWN	BAS
CHECKED	
APPROVED	

ADAM TECH
 909 Railway Avenue, Union, NJ 07083
 Phone: 908-687-5000 Fax: 908-687-5710

TITLE: **BNC, RIGHT ANGLE, 75 ohm**

SIZE: **X** PART NO.: **RF1-01A-P-00-75**

REF: SCALE: **NTS** SHEET **1** OF **1**